

WESTERSTRAND SPORTS SYSTEMS
Section Multi-purpose Scoreboards – LED



DESCRIPTION – BASIC MODULE LED-300-ICEHOCKEY ART NO 117220-64

Basic module LED-300 ICEHOCKEY is a single sided Scoreboard for indoor sports, with **integrated team name**

The Scoreboard is intended for wall mounting.

The delivery includes:

- 1 pc. Multi-purpose scoreboard (indoor use)
- 1 pc. Siren (built in)
- 1 pc. Wall mounting kit according to drawing 079855-00
- 1 pc. Instruction
- 1 pc Hard wired remote

**SPORTS: ICE HOCKEY - HANDBALL - VOLLEYBALL - TENNIS – TABLE TENNIS
BADMINTON – INDOOR FOOTBALL – FLOOR BALL - BOXING - WRESTLING
WEIGHTLIFTING - WATERPOLO – TIME KEEPING - GENERAL USE**



Scoreboard with built-in siren and four selectable sports or ice hockey (extra sports optional).

The design makes it suitable for most indoor sports and can also be combined with various add-on modules e.g. Penalty units etc.

It is controlled from our self-instructing remote control unit with pre-programmed rules which adapt the control unit to each individual sport.

The included remote control unit is hard wired, connection to Scoreboard acc to diagram on page 4.

Match/Game time	Count-up or down is indicated by four digits (minutes and seconds). As an option, regular day time can be indicated when no game is being played.
Game in progress/stopped	Indicated by green/red dot.
Score indication	00-99 (two digits per team)
Team name	4 characters/team (controlled from remote)
Period	1-9 (1 digit)
Time-out	By two yellow dots per team.
Siren	Count-down of time is indicated instead of match/game time (not in basketball). Built-in. Sounds automatically at finished game, time-out, break/pause and finished count-down of 24-seconds rule (basketball).
Front cover	By manually pressing a key, the siren can also sound at any other time. Non-reflective polycarbonate (DIN 18032) The front cover can be opened (equipped with hinges).

More detailed description of the function for each individual sports available on separate data sheets.

We reserve the right to make changes at any time.

E 926 A

WESTERSTRAND URFABRIK AB Sweden

P.O. Box 133, SE-545 23 TÖREBODA
E-mail: info@westerstrand.se

Tel. +46 506-480 00 Fax +46 506-48051
Internet: www.westerstrand.se



TECHNICAL DATA:

Case:	Aluminium profile
Colour of background:	Black
Front cover with hinges:	Polycarbonate, 3 mm
Digits:	LED's
Digit height:	Score, Time, = 300 mm Period = 250 mm
Colour of digits:	Yellow
Colour of matrix (team name):	Red
Size of dots:	Ø 40 mm
Colour of dots:	4 yellow, 3 red, 1 green
Exterior dimensions of case:	(WxHxD) 2200 x 1250 x 110 mm
Weight:	53 kgs.
Reading distance:	Approx. 150 metres
Connection voltage:	230V 50-60Hz AC
Power supply and electronics:	Built-in
Power consumption:	Electronics max. 200 VA
Ambient temperature:	± 0°C up to +40°C
Siren:	Built in, 117 dB

E 926 A

WESTERSTRAND URFABRIK AB Sweden

P.O. Box 133, SE-545 23 TÖREBODA
E-mail: info@westerstrand.se

Tel. +46 506-480 00 Fax +46 506-48051
Internet: www.westerstrand.se



MOUNTING:

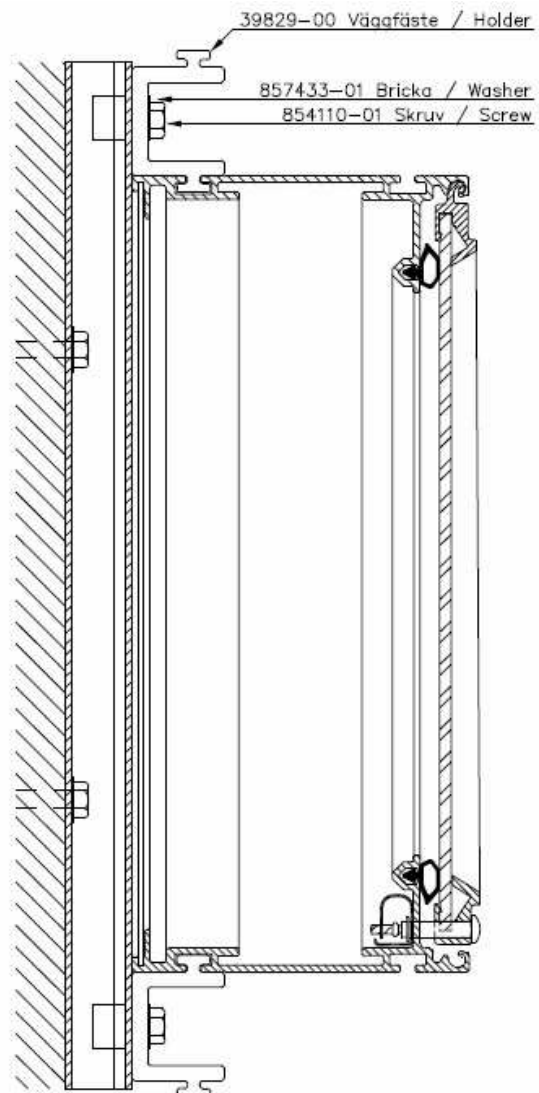
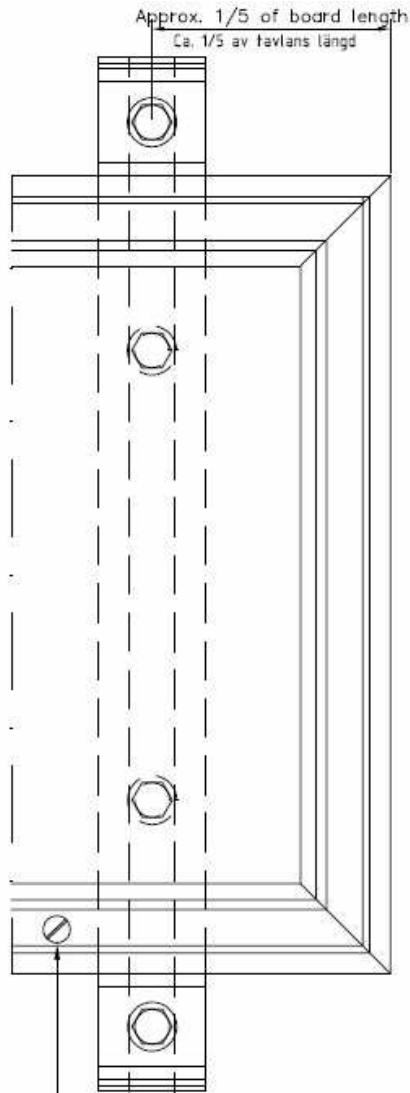

- 39822-00 Låsskruv / Locking screw
- 39823-00 Bricka / Washer
- Lossa dessa skruvar för att öppna tavlan
- Unscrew these screws to open the board

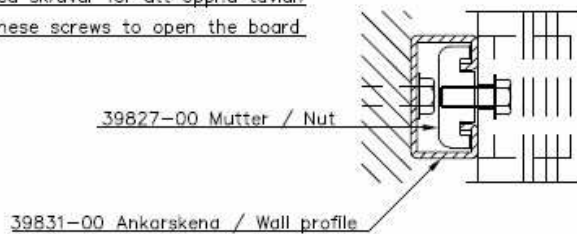

E 926 A

WESTERSTRAND URFABRIK AB Sweden

P.O. Box 133, SE-545 23 TÖREBODA
E-mail: info@westerstrand.se

Tel. +46 506-480 00 Fax +46 506-48051
Internet: www.westerstrand.se



DESCRIPTION: REMOTE CONTROL UNIT BASIC 117600-05

The TFT display shows the same information as the Scoreboard.
Easy to use through pre-programmed international rules.

Remote control Art.No. 117600-05 for hardwired operation of Scoreboards

The delivery includes:

- 1 pc. 22497-00 Remote control unit with pre-programmed sports
- 1 pc. 40536-42 Connection box

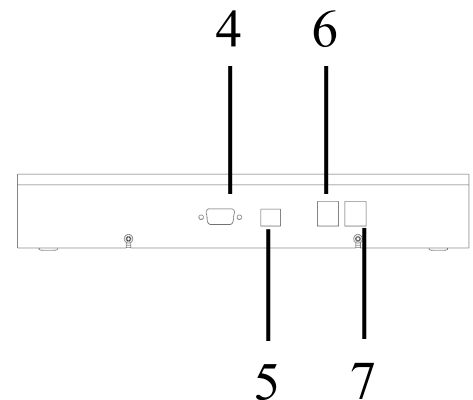
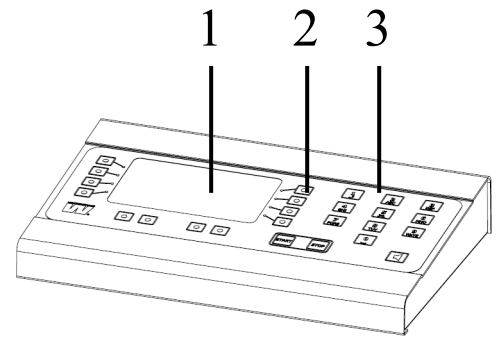

1. TFT display (800 x 480 pixels)
2. Function keys
3. Numeric keys
4. D-sub connector
5. USB connector
6. Connector for 24-seconds control handle
7. Connector for start/stop handle

TECHNICAL DATA:

Exterior measurements:

(WxHxD) 295 x 195 x 50 mm.

Weight:

1,2 kgs

Ambient temperature:

± 0°C up to +40°C.

Colour

Black casing with blue overlay

Case:

Aluminium

Connection to basic module:

See block diagram on next page. 3,0 metre cable with 5-polar audio connector and connection box are included in the shipment.

OPTION – see separate data sheets

- Start/Stop handle:
- Siren for medium and large halls
- Audio output – for siren
- RS 232 output
- Red/green referee lamps
- 114915-00 Bag for storage of remote

E 926 A

WESTERSTRAND URFABRIK AB Sweden

P.O. Box 133, SE-545 23 TÖREBODA
E-mail: info@westerstrand.se

Tel. +46 506-480 00 Fax +46 506-48051
Internet: www.westerstrand.se



CABLE DIAGRAM

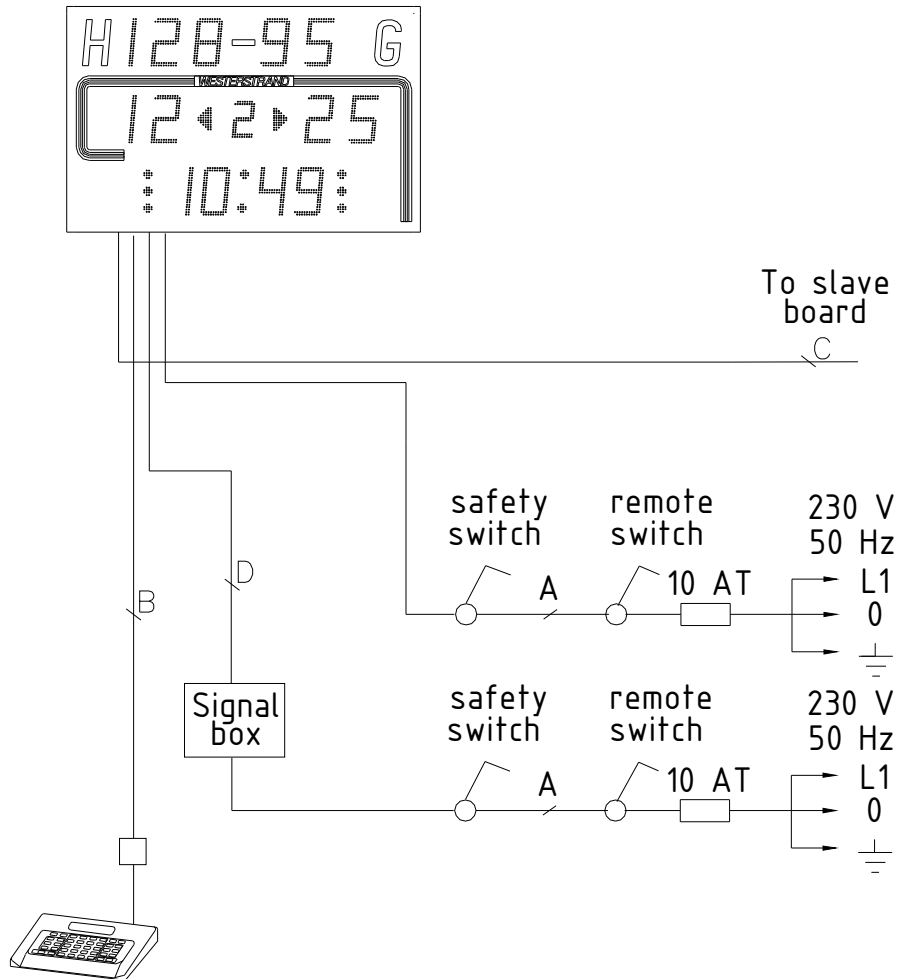

cable length m	A	B	C	D
< 50	3 x 1,5	4 x 0,5		
< 100		4 x 1,0		
< 150		4 x 1,5		
< 250		4 x 2,5	Cat 5	Cat 5
remark		screened	UTP	UTP

We reserve the right to make changes at any time.

WESTERSTRAND URFABRIK AB Sweden

P.O. Box 133, SE-545 23 TÖREBODA
E-mail: info@westerstrand.se

Tel. +46 506-480 00 Fax +46 506-48051
Internet: www.westerstrand.se

E 926 A