

SensolRIS BM60 SensolRIS BM120

Addressable linear detector using an optical light beam with reflector

ATTENTION: Read carefully this installation Instructions before installing the device! This manual is subject to change without notice!

CE 25
1293
DoP No: 273
Tested by EVPU

Teletek Electronics JSC
Address: 2 Iliyansko shose str,
1220 Sofia, Bulgaria

EN 54-12:2015
EN 54-17:2005
EN 54-17:2005/AC:2007

Attention: Integrated laser!
Do not stare or look directly into the beam lights!
Laser alignment (visible): 650nm

Indoor use IP65 UV PROTECTION

Temperature range: -10°C ÷ +60°C (93±3)%@+40°C

Cover frame ABS, white (RAL 9016)
Front cover PC, Violet fume
Rear cover ABS, black (RAL 9005)

0.5-2.5mm²

SensolRIS BM . . . ~520g
Reflector ~6g
Reflector set . . . ~530g

Models

The addressable beam detector is available in two models:

- SensolRIS BM60 for distances from 5m up to 60m, using one reflector plate (included).
- SensolRIS BM120 for distances from 50m up to 120m, using four reflector plates mounted to a metal frame (included).

ATTENTION: For simplicity of explanation hereafter in this document, we will use name SensolRIS BM, for reference to both SensolRIS BM60 and SensolRIS BM120 beam detectors. The specific options or operations concerning only one of the detectors are marked in an appropriate way pointing the concrete model.

General Description

SensolRIS BM is an addressable, reflector type, linear beam detector. The detector is compatible for operation with addressable fire alarm panels using TTE communication protocol - series iRIS4/8 and SIMPO X. The detector is powered on directly from the loop line or via using an external power supply unit, and can be controlled via the communication protocol.

SensolRIS BM consists of two parts: main module including a transmitter and a receiver of the emitted beam light, and a reflector plate. The main unit and the reflector are mounted facing each other on opposite walls of the protected premises, as there must be a clear direct (horizontal) viewing space between them without presence of any obstacles (as ducts, HVAC pipes, pending objects, etc).

The principal of operation of SensolRIS BM is based on detection of attenuation of the signal returned to the receiver. The reducing of the signal is due to obscuration of the light beam caused by visible smoke presence in the space between the main unit and the reflector. There are four sensitivity levels (alarm thresholds) for adjustment. Every one of them refers to a specific percentage of obscuration of the light beam - from 25% to 60%. The highest percentage refers to the lowest sensitivity. The sensitivity levels are selectable from the control panel and must be considered according to the environmental conditions on the site.

SensolRIS BM is equipped with built-in isolator module which when used allows continuous operation of the loop in case of detector's failure and without need of using additional isolator modules.

Self-compensation algorithms

SensolRIS BM is equipped with a micro-controller for continuously monitoring the quality and the strength of the returned signal.

During the time of operation is possible a thin layer of dust or dirt to accumulate on the lens thus reducing the signal strength. To avoid false alarms and faults, the micro-controller performs periodic automation check and applies algorithm for positive or negative compensation of alarm threshold if needed. When the applied algorithm for dust/dirt compensation reaches the threshold limits, the beam detector will generate a fault message for service maintenance and cleaning, and will enter in fault mode.

The micro-controller also contiguously checks for variations (increasing or decreasing) of the temperature in the protected premises. After completing the initial starting up procedures, the detector saves in its memory the current environment temperature as a reference value for assessment. A slight increasing of the signal may occur with the temperature rising and vice versa. In this case the detector applies algorithm for temperature compensation, as lowers or increases the signal amplification and thus avoids false alarms and fault conditions.

Main Advantages

- Combined transmitter and receiver in one unit, lower installation cost for cabling
- Temperature and dust/dirt compensation algorithms for minimizing of false alarms
- Built-in isolator module
- Detection of fires at very early stage, when the materials are still smoldering, and a smoke is only visible in the protected area
- Precise lens with fine adjustment of the optics
- Pluggable terminal blocks with color coding for easy wiring

Functional Features

- Range:
- SensolRIS BM60 from 5m to 60m
 - SensolRIS BM120 from 50m to 120m
- Alarm threshold (sensitivity), selectable from the control panel:
- Level 1 - Low Alarm Threshold 25% obscuration
 - Level 2 - Normal Alarm Threshold 35% obscuration
 - Level 3 - Medium Alarm Threshold 50% obscuration
 - Level 4 - High Alarm Threshold 60% obscuration
- Type of the reflector Prismatic
- Optical wave length - smoke detection - NIR* 950nm
- Max. angular misalignment:
- Detector ±0.5°
 - Reflector 1°
- Min. height mounting (people moving in the area) 2.7m
- Distance between two beam detectors 15m

* Near infrared, invisible

Technical Specifications - Loop Power

- Loop operation voltage 16-32V DC
- Consumption, without RI activated <6.4mA
- Consumption in alarm state, with RI activated <13mA

Technical Specifications - External Power Supply

- External power supply voltage 24V DC ±10%
- Loop operation voltage 16-32V DC
- Nom. consumption <5.5mA
- Consumption, without RI activated <1mA
- Consumption in alarm state, with RI activated <7mA

Technical Specifications - Isolator Module

- Maximum line voltage - V_{max} 32V
- Nominal line voltage - V_{nom} 28V
- Minimum line voltage - V_{min} 16V
- Maximum voltage at which the device isolates - $V_{so\ max}^{**}$ 7.5V
- Minimum voltage at which the device isolates - $V_{so\ min}^{**}$ 5.9V
- Maximum voltage at which the device reconnects - $V_{sc\ max}^{***}$ 6.7V
- Minimum voltage at which the device reconnects - $V_{sc\ min}^{***}$ 5V
- Maximum rated continuous current with the switch closed - $I_c\ max$ 0.7A
- Maximum rated switching current (e.g. under short circuit) - $I_s\ max$ 1.8A
- Maximum leakage current with the switch open (isolated state) - $I_l\ max$ 16mA
- Maximum series impedance with the switch closed - $Z_c\ max$ 0.12Ω@28VDC
0.15Ω@16VDC

** Note: Switches from closed to open

*** Note: Switches from open to closed



Unpacking

SensoIRIS BM60

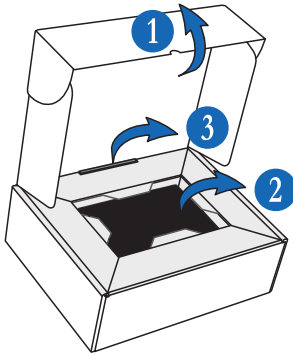

1. Open the packing box
2. Take out the Beam Detector
3. Take out the single reflector plate

SensoIRIS BM120

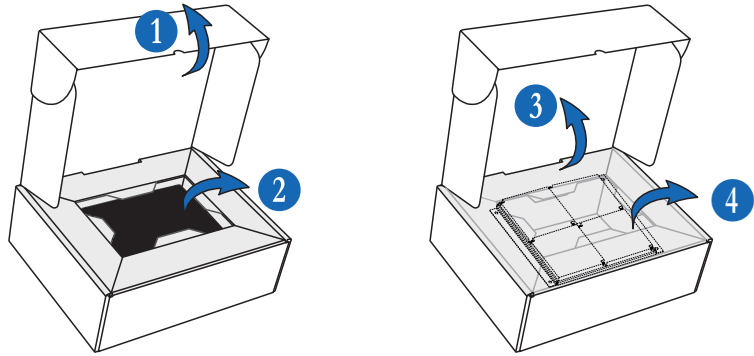

1. Open the packing box
2. Take out the Beam Detector
3. Pick up and open the internal paper holder, as tear its front side out and unfold it towards the cover of the packing box
4. Take out the metal frame with 4 reflectors from the bottom of the internal paper holder



Included parts and accessories

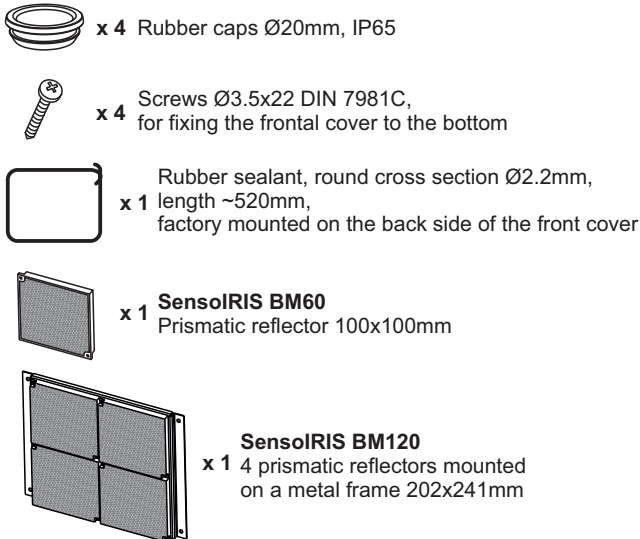

Dimensions

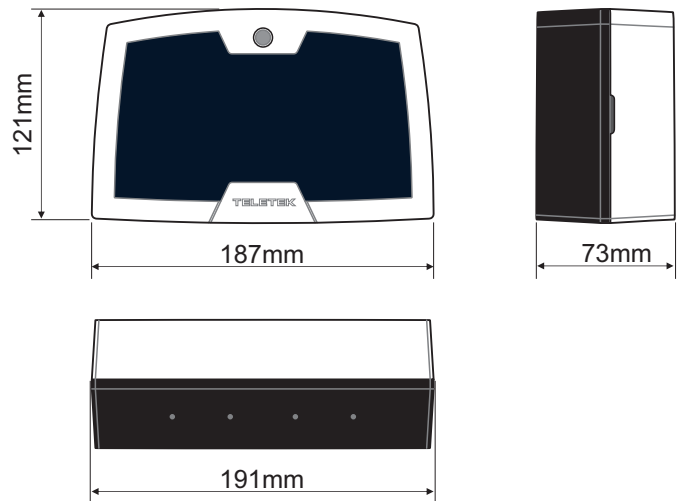

Opening of the housing box

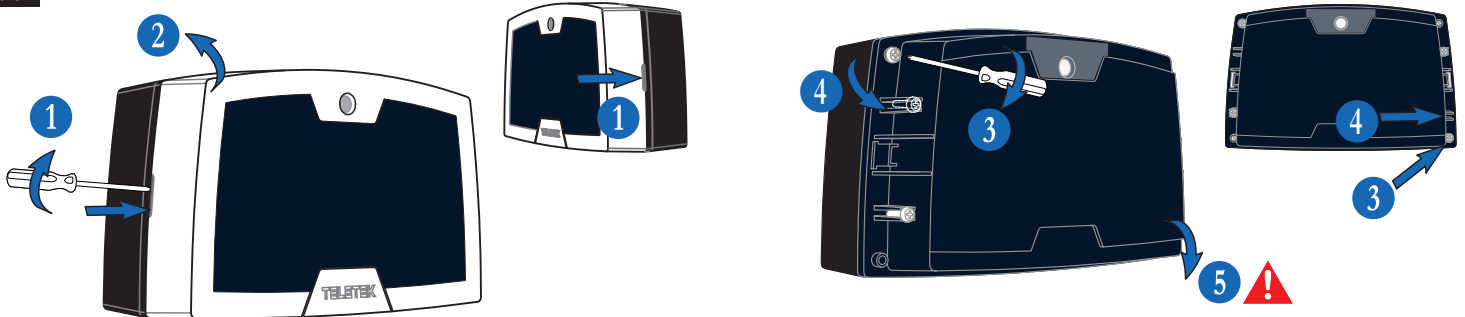

1. Use a flat screwdriver to unlock the front frame from the cover.
2. Remove the front frame and keep it in a safe place.
3. For a security reasons during transportation, the front cover is fixed to the bottom. Undo the screws using a crossed-slot screwdriver.
4. Place the screws in the free holders to keep them safe during mounting and wiring of the beam detector. (At this step, you can also mount back the front frame over the cover so to keep the both parts at the same place.)
5. Carefully tear rotating down the front cover. **Attention: Do not pull out!**
6. The front cover and the bottom are connected with a security rubber strip for protection during mounting or opening for maintenance.

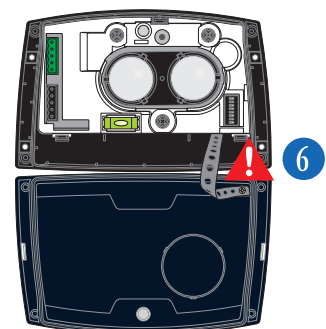

1 Elements of SensolRIS BM Beam Detector

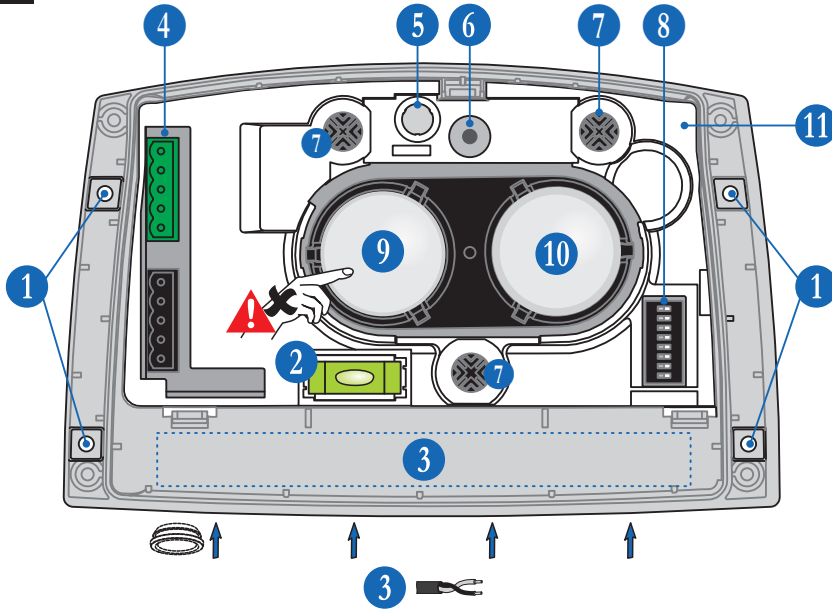

1. Mounting holes $\varnothing 3.2\text{mm}$. Use the drilling template given in item 13 to drill the mounting holes. Use appropriate fixing elements according to the mounting surface. For other details and specifics concerning mounting, see item 2.
2. Bubble lever.
3. Places for cable entry and space for running cables. Use a drill bit $\varnothing 2.2\text{mm}$ with hole saw $\varnothing 20\text{mm}$ to drill the holes for cable entry at the enclosure bottom. Place the rubber caps on the drilled holes. Run a cable through the center of the rubber cap, as if necessary widen the hole using a thin sharp tool. Do not cut the rubber cap - that will compromise the announced IP65 protection.
4. Pluggable terminals for connection of the electrical circuits. For details see item 3.
5. LED indication. For details see item 4.
6. Laser.
7. Handles for fine adjustment of the laser pointer and signal strength.
8. DIP-switches for operation and functional settings. For details see item 5.
9. Lens, transmitter section. Do not touch with bare hands!
10. Lens, receiver section. Do not touch with bare hands!
11. Protective cover for the PCB.

2 Considerations for position and location of mounting

Attention: SensolRIS BM is designed according to the requirements of EN 54-12. The detector and the reflector must be mounted also according to the local standards /regulations, laws, guidelines/, which can vary according to the different countries.

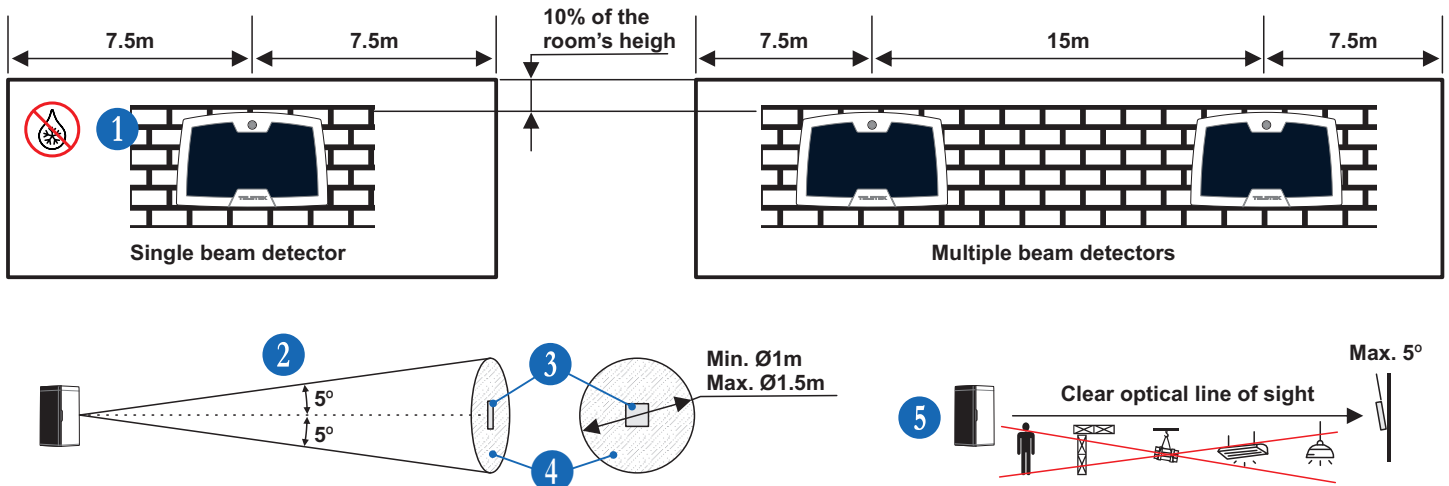

1. Mounting surface and surrounding environment. The mounting surface must be stable for proper operation of the device. It is not allowed the surface to move, vibrate, shift or bend under the influence of the surrounding environment or conditions, as thus will cause fault signals and alarms. **DO NOT** mount the detector on corrugated metal walls, sheets, siding coatings, suspended ceilings, rods, non-structural columns, plasterboard, clad walls, wood, or similar materials, as these surfaces are susceptible to movements. Mount the base of the detector on a solid stable surface as brick, concrete, or other load-bearing wall, support and structural columns, or surface that is not expected to experience vibrations or movements over time. The beam detector is mounted directly to the wall, with ensuring a downside cable entry. It is not recommended to mount the beam detector and/or the reflector at sites, where there is a high possibility of condensation and icing to occur. To avoid these undesired environment conditions and their influence on the proper operation of the beam detector, take respective preventing measures.

2. SensolRIS BM Beam Detector and the reflector must be mounted on the opposite walls at the one and the same height. It is allowed an angular error in positioning up to 5° in all directions.

3. Reflector. The reflector is mounted opposite to the detector. **DO NOT** mount the reflector on reflective or glass surfaces, places exposed on direct sun light, or with higher possibility of dust in the air caused from the surrounding environment conditions.

4. Diameter of clear space around the reflector. Ensure an area around the reflector free from other objects. The diameter can vary according to the distance of mounting and the model of the beam detector. To guarantee a proper operation it is recommended, when using SensolRIS BM60 (for distances from 5m to 60m) the clear space to be $\varnothing 1\text{m}$, and when using SensolRIS BM120 (for distances from 50m to 120m) the clear space to be $\varnothing 1.5\text{m}$.

5. SensolRIS BM must be mounted on a solid structure and with a clear line of sight to the reflector. **DO NOT** install the detector or the reflector behind glass or other transparent panels, that could compromise the operation. Avoid installation in areas with working processes and moving devices, pending fixtures, including lamps, in the operation space of the beam detector to guarantee its proper operation. The reflector has much more tolerance for movement than the detector, but it is allowed an angular error in positioning up to 5° against the mounting surface.

Diagram for reference between the required diameter of clear space around the reflector according to the distance to the Beam detector.

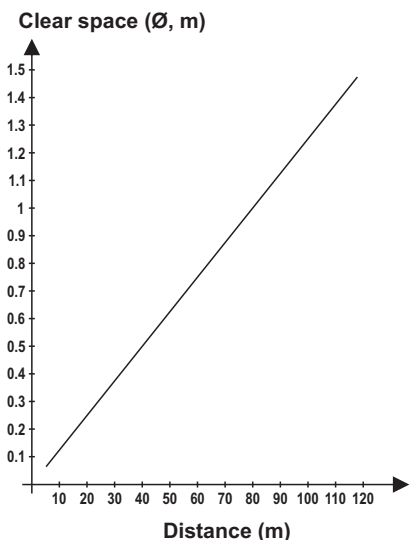

3 Wiring of SensoIRIS BM Beam Detector

Attention: Power off the loop line circuit before installing the SensoIRIS BM addressable beam detector!

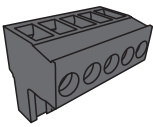

Loop line circuit

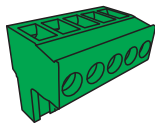

External power supply and remote indicator connection

SensoIRIS BM beam detector is delivered with two 5-pin plug connectors for quick wire installation, mounted to the terminals on the PCB. To unplug a connector, just pull it up from the terminal. To plug it back, press down until a click is heard. For easy cable installation the terminals are color coded. The black connector is for the loop circuit and the green one is for the external power supply and remote indicator (RI) connection. Use a flat screwdriver to undo/do the screws of the plugs.

Two connection diagrams are used according the type of power supply of the beam detector - direct power on from the loop line or using an external power supply unit. To use the built-in isolator module connect the positive loop line wire (Loop IN+) to the Izo terminal of the loop connector.

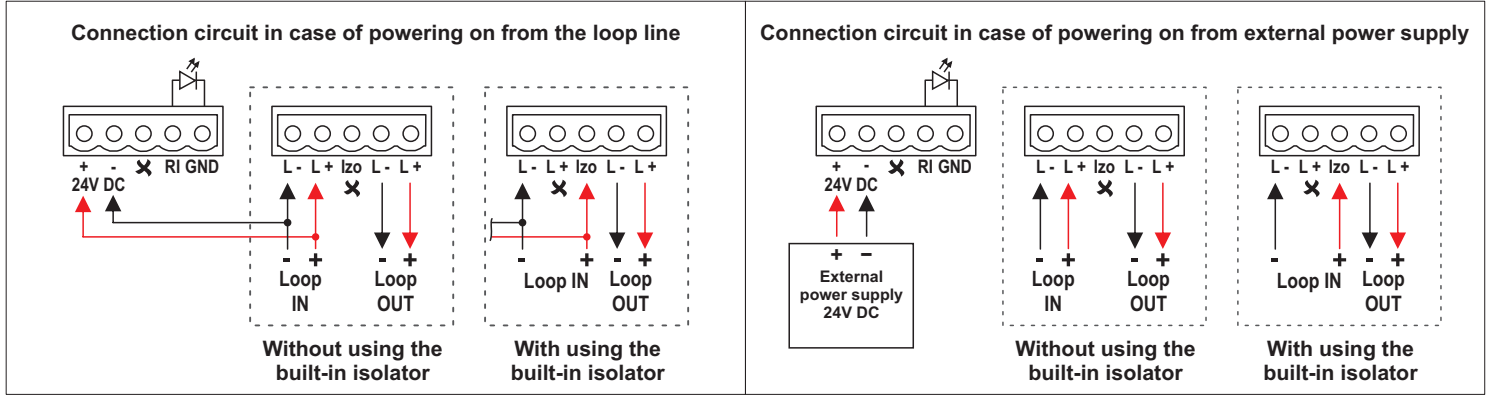

4 Operation Modes and LED Indication

4.1 Normal operation mode

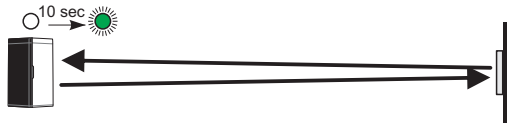

The emitted beam light is totally reflected and the strength of the received signal is 99-100% without loss.

LED Indication: The green led is flashing slowly (with 10sec interval).

4.2 Fault mode

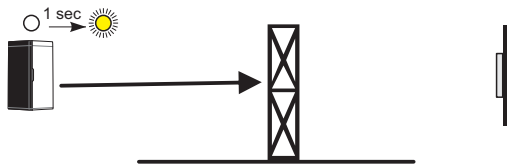

In case the emitted beam light is totally blocked and the reflected signal suddenly disappears at all, the detector will recognize this state as fault and will send a fault type message to the control panel. The detector will return to normal operation mode automatically after restoring the full reflection of the beam light (the strength of the received signal is 99-100% without loss).

LED Indication: The yellow led is flashing quickly (1sec).

4.3 Fire Alarm mode

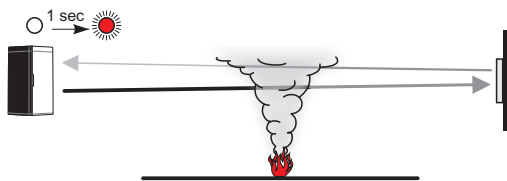

The emitted beam light is partially obscured by raising smoke. The reflected signal is attenuating with the gradually darkening in the space between the detector and the reflector. When the obscuration of the beam reaches the set alarm threshold level (see also item 6) the detector will send fire alarm message to the control panel.

LED Indication: The red led is flashing quickly (1sec).

5 DIP-Switches

SensoIRIS BM is equipped with DIP-switches used for calibration and operation processes. By default, DIP-switches 1-7 are set in OFF position, and DIP-switch 8 is ON position. To move a DIP-switch to ON position, use a small sharp tool or a small plain screwdriver.

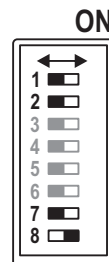

Some DIP-switches have different functions in OFF and ON position:

1. Switches ON/OFF the built-in laser pointer.
2. Switches ON the calibration process. In OFF position is enabled normal operation mode.
- 3-6. Not used. Must be in OFF position always.
7. Switch ON to enable Low power mode, when the laser point is activated (DIP 1 is ON).
8. Type of the detector - addressable device. **DO NOT change! It must be always in ON position!**

6 Programming the Alarm Thresholds

The alarm threshold is a specific value to which the SensoIRIS BM will react, when the smoke in the open space between the detector (receiver and the transmitter) and the reflector reaches a given level, called also obscuration, or darkening.

The operation of SensoIRIS BM can be set to react to different alarm threshold values, which define Levels (1-4) of sensitivity:

Level	Alarm Threshold	Obscuration	Sensitivity
1	Low	25%	High
2	Normal	35%	Nominal
3	Medium	50%	Nominal
4	High	60%	Low

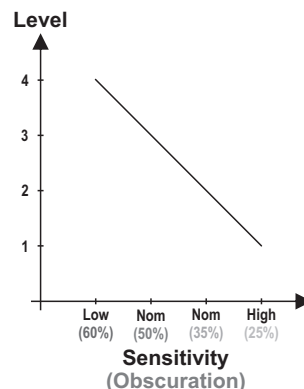

The set Alarm Threshold Level is inversely proportional of the sensitivity of the beam detector.

For the addressable detector SensoIRIS BM, the settings for the alarm threshold levels (sensitivity) are set via the used fire alarm panel iRIS8, iRIS4, or SIMPO X. The functionality of the panel allows to be set two different values for Day and Night alarm level - see item 12.

7 Installation Steps

Attention: In case of initial power up of a brand new SensoIRIS BM beam detector the LED indication is alternative slowly flashing of the yellow and green LEDs. It is important to know that the beam lights (one emitted from the transmitter and the second received from the receiver) are factory optically phased to ease the alignment procedure. After the initial power up, the beam detector automatically start self-setting, so that the received signal is to be with value of 50% sensitivity.

1. Following the considerations in item 2, choose the place of installation and mount the detector and the reflector at the same height, on opposite walls, facing each other.
2. Run the cables as described in item 1. Follow the connection diagrams in item 3 for details. Note that, all the wiring must be done with loop circuits power off.
3. Check the position of DIP-switch 8. **It must be in ON position.**
4. Power on the loop line. Power on the external power supply unit if such is used. The yellow and green LEDs are flashing slowly (alternative).
5. Move DIP-switch 1 in ON position. That will activate the laser point. A red dot on the opposite wall will start blinking quickly. (To lower the power consumption of the detector at this step you can switch ON DIP-switch 7 - the red dot will start blinking slowly.)
6. Focus the beam light in the center of the reflector as using the handles (rotation on the left-side or on the right-side) for fine adjustment.

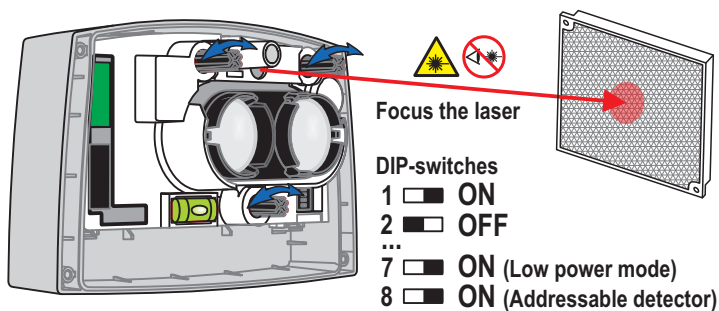

7. Switch OFF DIP-switch 1.
8. Switch ON DIP-switch 2. This enables the procedure for alignment and calibration of the detector for receiving the reflected signal with a maximum strength. The red and green LEDs will blink quickly at the beginning during the self-tuning phase.
9. For the adjustment of the reflected signal strength, use the handles again doing little rotations on the left-side or on the right-side, as look for the indication of the green LED. The calibration is done when the green LED start flashing steadily (1 blink in 1.5sec).

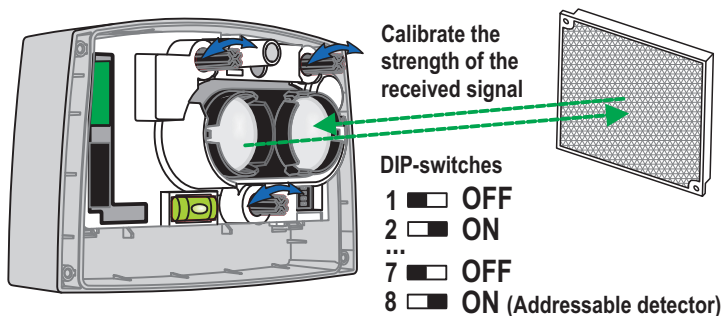

Calibration Tips. Make the calibration with little rotations only. Do not rotate all the handles at the same time. If the signal is lost, rotate the handle in the opposite position. The steady blinking of the green LED is possible to start immediately after self-tuning phase. In this case is recommended to leave the position of the handles as they are.

Troubleshooting. If during the calibration the red LED start blinking or the yellow LED is permanently lighting on, this means that the reflected signal is lost (too low), or is out of range. If it is impossible to make the adjustment rotating back the handles and the process fails, it is recommended to power off the detector, move DIP-switches 1 and 2 in OFF position and to start the calibration procedure again (start from point 4). If the calibration continuously fails, ask for support your local distributor.

10. To end the calibration procedure, switch OFF DIP-switch 2.
11. The yellow LED start blinking in a scheme - 2 slow blinks followed by 2 quick blinks. The detector enters in a special stand-by mode for the next 5 minutes. During this period the installer must mount back the front cover and the frame. The front cover must be fixed to the bottom with the screws.
12. When the stand-by mode is over, the detector enters into Normal operation mode as the strength of the received (reflected) beam light is taken set as 100% (the highest possible). The green LED is blinking over 10 seconds.

8 Address Programming

SensoIRIS BM is an addressable detector and operates via TTE Communication protocol. The address number can be set in advance using SensoIRIS Programming tool, or can be assigned after connection to the addressable fire alarm panel - iRIS4, iRIS8, or SIMPO X.

- When setting the address with SensoIRIS Programmer, use the cable with the 5-pin terminal to connect to the loop connector (black) on the PCB.
- The addressable panel recognizes the beam detector with service name "BM60/BM120". Then follow the standard procedure for adding the new devices to the system configuration.

Refer also to the Programming manual of the control panel for details - visit the Teletek Electronics JSC portal for more information and technical manuals download: <https://portal.teletek-electronics.com/>

9 Test of the Sensitivity

It is recommended to test the sensitivity of the beam detector periodically according the local regulations and country guidelines. For the test is used a filter hard folio with gradually darkening grey scale from 10% to 100%.

1. From the control panel, enable a Zone Test for the zone number to which the beam detector is associated.
2. Check the set sensitivity levels for Day and Night Alarm modes - 25%, 35%, 50%, 60%, and define the corresponding darkening on the filter folio for reference.
3. To test the sensitivity, place the filter folio in front of the beam detector with corresponding to the set Day/Night alarm threshold darkening (25% - 60%) and hold it for a minute. The time for reaction depends also and if there are set times for delaying of fire alarm messages (see item 12).
4. To test the response for fault, place some blocking material, or the most dark section of the filter, in front of the beam detector. The sudden lost of the signal will bring the beam detector in Fault mode.
5. After completing the tests for sensitivity and faults, remove the filter and leave the beam detector to return to normal operation mode.
6. Exit Zone test mode.
7. Reset the control panel from the main screen.

10 Maintenance and Cleaning

The manufacturer recommends to provide regular maintenance of the beam detector, including visual observation of the detector enclosure box and the reflector, and cleaning of the outside surfaces.

According the type of the protected site and the working processes a fine dust layer is possible to accumulate on the detector and the reflector. The dust can block partially the signal or to reduce the strength of the reflected beam.

Clean the surfaces with a soft cloth. Do not use abrasive or aggressive cleaning detergents or solvents, as they can harm the prismatic surface of the reflector and to scratch or damage the frontal cover of the beam detector.

Provide the maintenance and cleaning regularly according the environmental conditions, and extraordinary after completing construction repairs or renovations provided at the protected site.

11 Factory Reset

The factory reset is allowed only in case of moving the detector to different site and different environment conditions, and/or assigning to new addressable control panel.

The factory reset is done with a special mini button (SW2) on the detector's PCB. To access the button, first you must to remove the frame and the front cover as described on page 2. Then remove the pluggable connectors. Then you must remove the protective cover above the PCB - it is fixed to the bottom via clips - two at the bottom side, and one on the upper side. Use a plane screwdriver to unlock the clips. Remove the protective cover. The SW2 button is situated under the receiver lens. Power on the detector and press for 5-10 seconds the reset button. The yellow and green LEDs will start blinking alternatively - this is the common indication for initial power up. Disconnect the power supply and mount the protection cover back in place. Pay special attention to the protective strip for holding the frontal cover - the last hole of its end must be fixed on to the pin under the opening for the DIP-switches terminal.

Proceed following the mounting and installation instructions given above.

12 Programming Parameters - iRIS4, iRIS8, SIMPO X

Addressable beam detector SensolRIS BM is compatible for operation with addressable control panels supporting TTE communication protocol. After connection and adding to the system configuration SensolRIS BM enters in normal operation mode - the system status is presented on the main screen of the device.

iRIS4 and iRIS8 Addressable Fire Alarm Panels

Access to the beam detector settings is done in engineering programming menus, for users with Access level 3. From the main screen of the panel, enter in sequence: *System - Programming - Device - Loop*, and find the exact address of the beam detector.

The screenshot shows the main screen of the fire alarm panel. At the top, it displays 'TELETEK' and 'BM60/BM120' with a status of 'Enabled'. Below this, there are buttons for 'TURN ON', 'Normal', and 'Remove'. A 'Name' field is present. On the left, there are indicators for '0 Alarms', '0 Faults', and '0 Warnings'. At the bottom, there are buttons for 'EXIT', 'MENU', 'Access 3', and 'MORE'.

The panel recognizes the detector with system name "BM60/BM120". The user can enter and additional name or longer description (up to 40 symbols, including spaces) in "Name" field.

To access the additional settings, press MORE button.

The screenshot shows the 'MORE' settings screen. It includes fields for 'Device Zonal Address' (set to 0), 'Real-time value' (set to 100), 'Device Group' (No RI Out, 0), 'Day Alarm Level' (25%), and 'Night Alarm Level' (60%). Other fields include 'Normal operation' (Already aligned), 'Software Revision' (X.XX), and 'ID' (XXXXXXXXXX). Buttons for 'EXIT', 'MENU', 'Access 3', and 'MORE' are at the bottom.

The user can set the alarm threshold values for Day and Night alarm levels in the respective active fields. To change the value, press the button. With the keyboard presented on the screen, enter new value and press OK. Note that, you can set exact values (25%, 35%, 50%, 60% announced in the beginning of this manual, or set other values around them).

Other special fields in this screen are:

- "Real-time value" - this value is read at the moment, and represents the strength of the reflected signal received from the detector. At the initial power up of the detector, before performing calibration procedure, the value in the field is 50%, and this is normal.
- "Normal operation" - in the field is presented information about the status of the calibration process. When the calibration is completed, the message is "Already aligned". At the initial power up of the detector, before performing calibration procedure, the message in this field is "New from factory". Same message is presented in the field and after making a hardware reset of the detector.

The rest of the fields are common for all devices SensolRIS series and their detailed description is available in the "Engineering programming manual" of iRIS4 and iRIS8.

Press MORE button again to access next screen with special settings.

The screenshot shows the special settings screen. It includes a 'Led Blink' setting (ON), 'Day Mode' settings for 'Alarm delay time' (5) and 'Fault delay time' (60), and 'Night Mode' settings for 'Alarm delay time' (5) and 'Fault delay time' (5). There are also indicators for '0 Alarms', '0 Faults', and '0 Warnings'. Buttons for 'EXIT', 'MENU', 'Access 3', and 'MORE' are at the bottom.

In the next screen, the user sets the time for reaction of the panel, after an alarm or fault signal is received from the detector. The settings are available for Day and Night operation modes. In the corresponding active fields the user sets a time for delay in seconds:

- "Alarm delay time" - set a time in range 5-30 seconds for delaying the announcement for fire alarm signal from the detector. In case of alarm signal, the panel will wait the set delay time to end before starting the sounders for fire alarm and evacuation on the site.
- "Fault delay time" - set a time in range 5-60 seconds for delaying the announcement for fault signal from the detector. In case of fault signal, the panel will wait the set delay time to end before register the fault message in the memory log. This setting is useful for premises with active working processes, where is possible to move tall objects in the area between the detector and the reflector. Blocking the beam for a short time will not affect the normal operation of the control panel and the fire alarm system. With setting a time delay for reaction to alarm or fault conditions, is a way to avoid or to minimize the false alarms caused by daily working processes or short-term environment conditions.

To return to main screen of the device press EXIT button.

The new settings must be confirmed with "Apply" button on the main screen of the device.

The screenshot shows the main screen of the fire alarm panel, identical to the first screenshot, but with the 'Apply' button highlighted in red.

SIMPO X and SIMPO X NL Addressable Fire Alarm Panels

All parameters described above are accessible for settings in SIMPO X series panels in Engineering programming menus (Access level 3). Press ESC button and enter code for access to engendering programming. Select menu "Devices" and press ENTER. Find the address number of the SensolRIS BM and press ENTER again. In the following menus use the keyboard to set the specific values. All settings must be confirmed with OK button.

For more information, and to download the engineering programming manuals of the compatible addressable fire alarm control panels, scan the QR codes for access to Teletek Electronics JSC database library portal.



13 Drilling Template

Use the drilling template of the bottom (scale 1:1) for precise drilling holes on the mounting surface. Use a drilling bit $\varnothing 3/3.5\text{mm}$ and suitable fixing elements according the mounting surface.

